

A2

A3



BAT Engineering Systems

DATA SHEET

## Self Drill Self Tap Screw Installation Instructions

Drill the screw into the steel work using an appropriate drive using the tie as a template. Ensure the isolation patch is positioned between the tie and the steelwork and that the screw is perpendicular to the steel work. It is important to check that the drill speed is set to 1500-2500 RPM.

Tie position to be strictly in accordance with Expamet Construction project drawings. Make sure that the screw is of the right diameter and length prior to installation. To avoid damage to the screw do not over tighten.

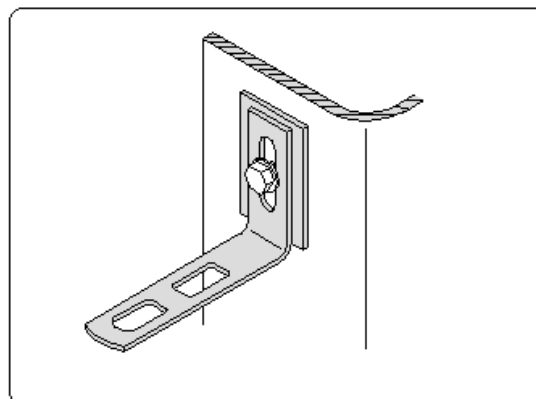
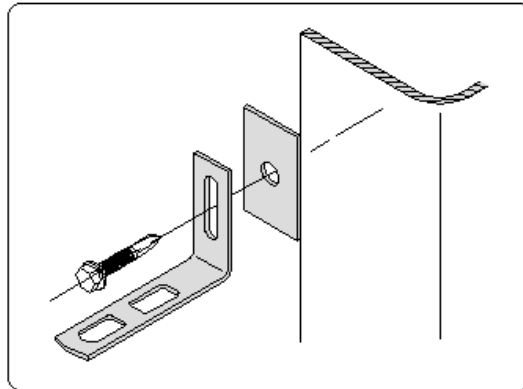



# Self Drill Self Tap Screw Installation Instructions

## Contact information

Technical:  
Telephone 01429 866655  
Email [technical@expamet.net](mailto:technical@expamet.net)  
Fax 01429 866622

Sales:  
Telephone 01429 866611  
E-mail [sales@expamet.net](mailto:sales@expamet.net)  
Fax 01429 866622

## Expamet Health and Safety

### 1. IDENTIFICATION

Expamet Building Products Limited  
Greatham Street  
Longhill Industrial Estate (North)  
Hartlepool TS25 1PU  
United Kingdom  
Tel: +44 (0)1429 866688  
Fax: +44 (0)1429 866633

### 2. COMPOSITION

Stainless steel 1.4301 to BS EN 10088-1: 2005

### 3. HAZARDS IDENTIFICATION

Possible cuts from steel edges.  
Toxic and irritant fumes from high temperatures.

### 4. FIRST AID MEASURES

Skin and eye contact: treat cuts from steel edges as required.  
Ingestion: not applicable.  
Inhalation: remove from source of fumes and dust.

### 5. FIRE FIGHTING MEASURES

Non-flammable material.

### 6. ACCIDENTAL RELEASE MEASURES

Not applicable.

### 7. HANDLING AND STORAGE

Use suitable PPE when handling all products. Assess manual handling risks before lifting. All products should be stacked on firm level ground in dry conditions.

### 8. EXPOSURE CONTROLS

Wear personal protection such as gloves and safety goggles when handling products.  
Some products may have a film of soluble cutting fluid after manufacture; therefore carry out personal hygiene, including proper washing of hands, after contact.

Expamet operates a continuous development programme and we reserve the right to amend specification with prior notification

